

Tray and Rack Dolly

Model

TD-100-AF

This sturdy yet lightweight aluminum tray dolly solves the problem of transporting trays or wire racks from the kitchen cleaning area to the assembly line. In addition, it is useful in transporting soiled trays to the cleaning area. Five of the 20" square racks or ten of the half-size racks can be stacked and transported safely and securely.

PRODUCT INFORMATION

- Cart shall be lightweight aluminum, 37" high and weigh 32 lbs. Platform 21 $\frac{3}{4}$ " x 21 $\frac{3}{4}$ " to hold 20" x 20" or 10" x 20" wire racks.
- Useful in transporting soiled trays to the cleaning area.
- Can be used to transport trays or wire racks to the assembly line.
- Transports safely and securely.
- Optional correctional package available.

Tray and Rack Dolly

TD-100-AF

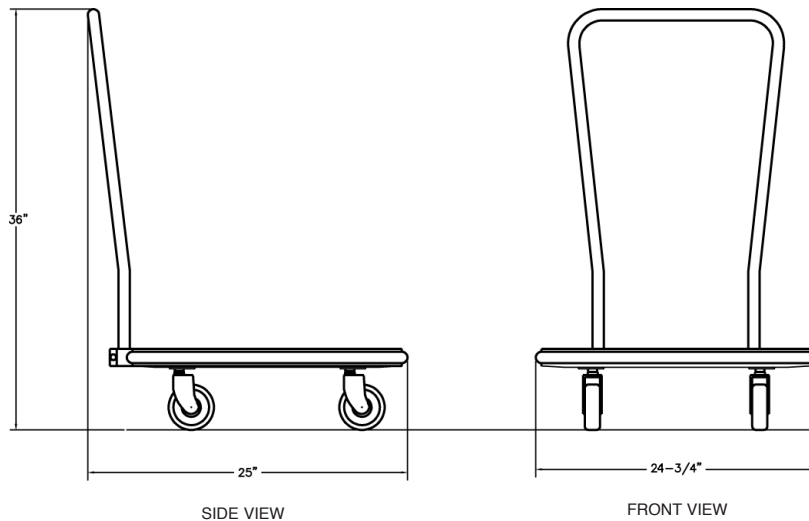

TECHNICAL SPECIFICATIONS

Model	Dimensions			Notes	Shipping Weight
	W	D	H		
TD-100-AF	25"	24 ³ / ₄ "	36"	Capacity: 5-20" x 20" racks or 10-10" x 20" racks or 100 trays. 4-4" swivel casters standard.	50 lbs.

BID SPECIFICATIONS

Provide (1) model ___ Tray and Rack Dolly. Unit to be manufactured of aluminum.
Unit to hold (5) 20" x 20" racks.



Savannah, TN 38372 www.americanfoodserviceco.com
731-925-2200 / 800-447-4693 / FAX 731-925-2840

Due to continued product improvement, specifications are subject to change without notice.

9/01/11 USA