



Mobile Rack/Cart

Models

Aluminum

A1826-5ST-AF

A1826-5STO-AF

*For 18 x 26 pans, stainless steel top,
standard duty 1-³/₁₆" uniledge*

FEATURES

- **Application:** Well suited as a mobile work surface, slicer or mixer stand and for tray transport in a wide variety of standard duty applications.
- **Design & Construction:** One-piece, 14 gauge, high strength aluminum side panels with die formed 1-³/₁₆" wide uniledges. Cross members are 14 gauge formed aluminum with 12 gauge stainless steel gussets. **Model A1826-5ST-AF** has a stainless steel top and **Model A1826-5STO-AF** has a stainless steel top with (2) side outrigger channels.
 - Optional correctional package available.

PRODUCT INFORMATION

- **Design Features:** Uniledge side panels provide strength and easy cleaning and have a corrosion resistant coating. Cross members and gussets are riveted to create the high strength "I-Beam" assembly. Exclusive, "long angle" mounting bracket on casters assures rigidity. STO — Stainless steel top with outrigger channels on each side allows the attachment of (2) 18 x 26 or (4) 18 x 13 pans, creating an additional 6-¹/₂ sq. ft. mobile work surface.
- **Caster Type:** 5" dia., standard duty, swivel, neoprene wheels, angle mounting bracket. Two casters supplied with brakes.
- **Ledge Load (Max.):** 15 lbs. per ledge
- **Spacing:** 4" between ledges.
- **Pan Accommodations:** (5) 18" x 26" or (10) 18" x 13" pans.
- **Warranty:** One full year on parts and 90 days on labor from date of initial installation, covering defects in material or workmanship, excluding problems resulting from lack of normal maintenance, misuse and abuse.

Mobile Rack/Cart

A1826-5ST-AF, A1826-5STO-AF

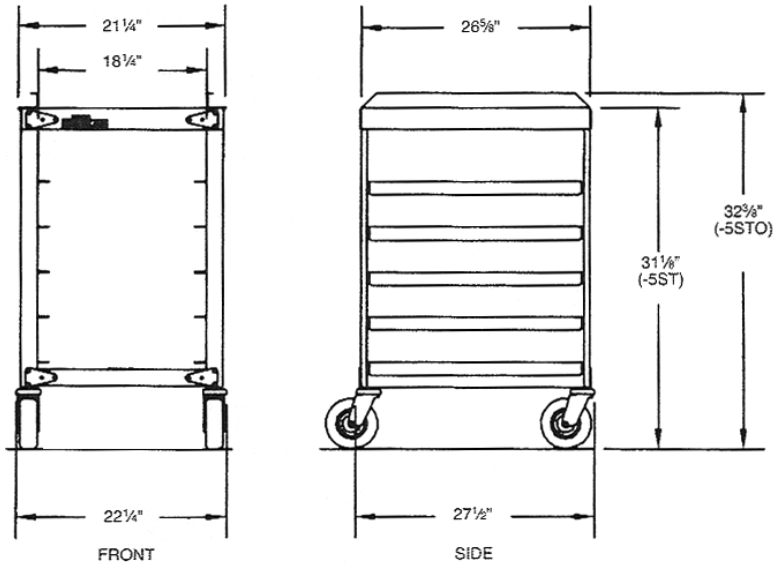

TECHNICAL SPECIFICATIONS

Aluminum Model	Overall Dimensions				Weights (lbs.)		Shipping Dim. (in.)			Cu. ft.
	Width	Depth	Height	Height with outriggers	Net	Ship	Width	Depth	Height	
A1826-5ST-AF	22-1/2"	26-3/8"	31-1/8"	32-3/8"	24	30	26	34	37	18.9
A1826-5STO-AF					26	32				

BID SPECIFICATIONS

Provide (1) model _____ Mobile Rack/Cart with stainless steel top.

Construction shall be (1) piece, die formed, corrosion resistant coated aluminum uniledge side panels with integral 1-3/16" wide ledges spaced 4" apart with top and bottom I-beam cross braces, 16 gauge stainless steel top.

Provide with (4) 5" swivel casters, (2) with brakes, having neoprene wheels and vertical angle mounting brackets.

Must be NSF approved.



Savannah, TN 38372 www.americanfoodserviceco.com
731-925-2200 / 800-447-4693 / FAX 731-925-2840