



Model HQ-HA-AF shown

Banquet Cart-HQ

Models

HQ-HA-AF Heated & Ambient
 HQ-HH-AF Heated
 HQ-HR-AF Heated & Refrigerated
 HQ-RR-AF Refrigerated

This unit designed specifically for delivery of foods in 18 x 26 sheet pans or 12 x 20 steam table pans, preplated foods in a banquet environment, or correctional trays.

OPTIONAL ACCESSORIES

- Optional correctional package available
- Optional refrigerated module available
- Optional tray guides or stacking shelves for correctional trays

PRODUCT INFORMATION

- **DESIGN & CONSTRUCTION:** 18 gauge formed and welded body and door with 20 gauge interior liner, Fiberglass insulated, perimeter bumper and side handles.
- **DESIGN FEATURES:** Fully insulated for maximum temperature retention. Electronic temperature controller for temperature monitoring.
- **THERMOSTAT RANGE:**
 Refrigerated: 33°F - 41°F.
 Heated: 60°F - 185°F.
- **ELECTRICAL SPECIFICATIONS:** The heated ambient cart operates on 120 volts, 15 amps, 60 Hz, 1 ph, and the refrigerated cart operates on 120 volts, 20 amps, 60 hz., 1 ph.
- **CASTER TYPE:** Heavy duty, (4) swivel with brakes and (2) rigid, all with semi-rigid wheel. 8" dia.
- **OPTIONAL:** Refrigerated module available.

Banquet Cart-HQ Series: Ambient, Heated or Refrigerated

HQ-HA-AF, HQ-HH-AF, HQ-HR-AF, HQ-RR-AF

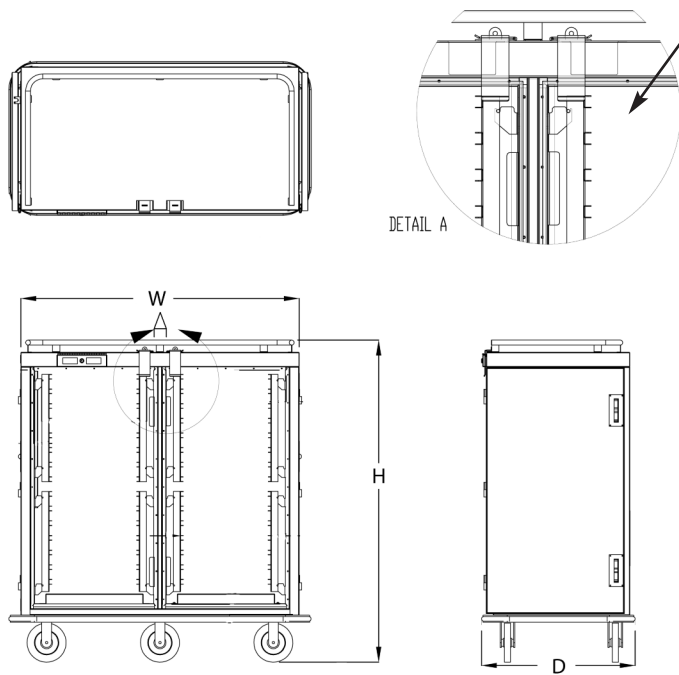

* Optional bulk transport adjustable pan ledges for (15) 18 x 26 pans or (30) 12 x 20 x 2½ pans per compartment.

ELECTRICAL

Heated: 120V / 60Hz / 1ph
120 Volts, 15 Amps

Refrigerated: 120V / 60Hz / 1ph
10 Volts, 20 Amps

TECHNICAL SPECIFICATIONS

Model	Shelf size (in.)	Clearance between shelves (inches)	Width (inches)	Depth (inches)	Height (inches)	Weight (lbs.) Class 100 Shipping
HQ-HA-AF	22x32½	13⅜	40⅝	30½	54¼	290
HQ-HH-AF	22x42½	13⅜	50¼	30½	54¼	358
HQ-HR-AF	22x42½	16⅝	50¼	30½	64¾	390
HQ-RR-AF	22x22½	16⅝	61½	30½	64¾	442

BID SPECIFICATIONS

Provide (1) model ___ Banquet cart.

Exterior body shall be constructed of 18 gauge stainless steel, formed and welded to form a smooth one-piece unit. Interior liner shall be constructed of 20 gauge stainless steel with all corners covered for easy cleaning. Joints and seams to be closed and sealed. The chassis shall be constructed of 14 gauge square frame material reinforced with steel plate at all corners.

Door shall be double wall stainless steel construction with gasket and insulated.

Insulation shall be continuous wraparound fiberglass. Push handles shall be mounted on each end of cabinet. Casters shall be heavy duty, 8" diameter semi-rigid, four swivel and two rigid. Heating assembly shall be non-removable; AC with thermostatic control; heated units calibrated from 60°F - 185°F, refrigerated units calibrated from 33°F - 41°F. Perimeter bumpers shall be non-marking vinyl mounted into a clincher-type channel.



Savannah, TN 38372 www.americanfoodserviceco.com
731-925-2200 / 800-447-4693 / FAX 731-925-2840

Due to continued product improvement, specifications are subject to change without notice.

9/01/11 USA