

Dining Cart-DC

Models

DC-HH-AF Heated & Heated

DC-HR-AF Heated & Refrigerated

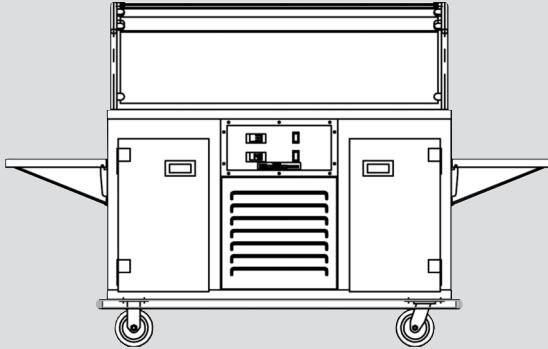

This unit designed specifically for delivery of foods in 12 x 20 steam table pans, preplated foods in a banquet environment, or compartmented trays.

OPTIONAL ACCESSORIES

- Stone Top Deck (Zodiac, CaesarStone...)
- Stainless Steel Tray Slide
- Plastic Laminate Body Panels
- Stainless Steel Folding Work Shelf
- Folding Work Shelf with NSF Approved Plastic Cutting Board
- Folding Work Shelf with Hardwood Cutting Board
- Folding Work Shelf with Heat Resistant Richlite
- Stainless Steel Folding End Shelf (specify 1 or 2)
- Breath Protectors: Fixed
- Breath Protectors: Adjustable
- Breath Protector with Stainless Steel Overshelf
- Stainless Steel Condiment Overshelf Tray Starter
- Facility Logo
- Electrical Raceway and Junction Box
- Bullet Feet
- Correctional Package

PRODUCT INFORMATION

- **DESIGN & CONSTRUCTION:** 18 gauge formed and welded body and door with 20 gauge interior liner, Fiberglass insulated, perimeter bumper and side handles.
- **DESIGN FEATURES:** Fully insulated for maximum temperature retention. Electronic temperature controller for temperature monitoring.
- **THERMOSTAT RANGE:**
Refrigerated: 33°F - 41°F.
Heated: 60°F - 185°F.
- **ELECTRICAL SPECIFICATIONS:** The heated ambient cart operates on 120 volts, 15 amps, 60 Hz, 1 ph, and the refrigerated cart operates on 120 volts, 20 amps, 60 hz., 1 ph.
- **CASTER TYPE:** Heavy duty, (4) swivel with brakes and (2) rigid, all with semi-rigid wheel. 8" dia.
- **OPTIONAL:** Refrigerated module available.

Dining Cart-DC Series: Ambient, Heated or Refrigerated

DC-HH-AF, DC-HR-AF

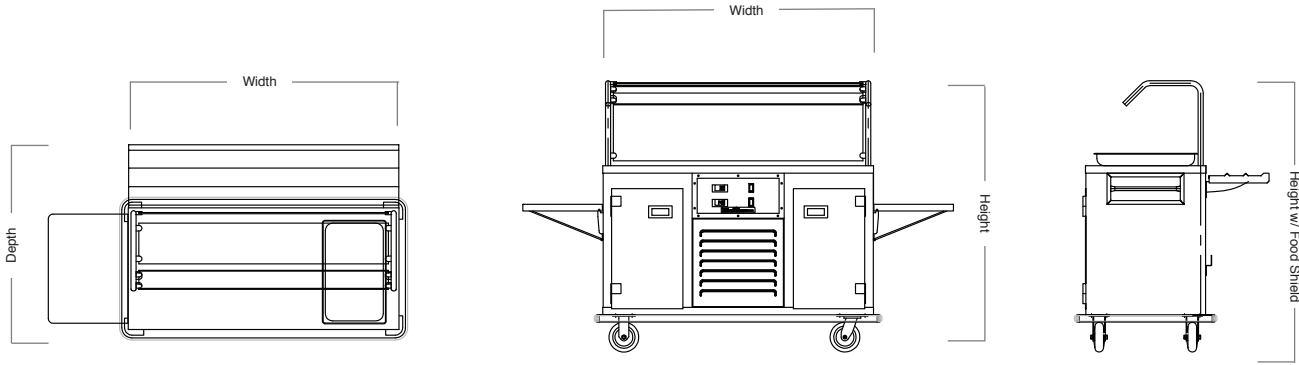

ELECTRICAL

Heated: 120V/60Hz/1ph
120 Volts, 15 Amps

Refrigerated: 120V/60Hz/1ph
10 Volts, 20 Amps

TECHNICAL SPECIFICATIONS

Model	Pan size (in.)	Capacity Comp/Total	Clearance between shelves (inches)	Width (inches)	Depth (inches)	Height to counter top	Weight (lbs.) Class 100 Shipping	Height w/ Food Shield
DC-HH-AF	22x42½	8/16	13¾	58	28¾	37½	358	54⅝
DC-HR-AF	22x42½	8/16	16¾	58	28¾	37½	390	54⅝

BID SPECIFICATIONS

Provide (1) model ___ Dining Room Cart.

Exterior body shall be constructed of 20 gauge stainless steel, formed and welded to form a smooth one-piece unit. Top deck is constructed of 16 ga. stainless steel. Interior liner shall be constructed of 20 gauge stainless steel with all corners covered for easy cleaning. Joints and seams to be closed and sealed. The chassis shall be constructed of 18 gauge material top and as a serving top.

Door shall be double wall stainless steel construction with gasket and insulated.

Insulation shall be continuous wraparound fiberglass. Push handles shall be mounted on each end of cabinet. Casters shall be heavy duty, 6" diameter semi-rigid, four swivel and two rigid. Heating assembly shall be non-removable; AC with thermostatic control; heated units calibrated from 60°F - 185°F, refrigerated units calibrated from 33°F - 41°F. Perimeter bumpers shall be non-marking vinyl mounted into a clincher-type channel.



Savannah, TN 38372 www.americanfoodserviceco.com
731-925-2200 / 800-447-4693 / FAX 731-925-2840

Due to continued product improvement, specifications are subject to change without notice.

11/01/11 USA