

# Tray and Silverware Counter

## Model

TS-28-AF

TS-32-AF

### OPTIONAL FEATURES

- Solid Surface Top Deck (Corian...)
- Stone Top Deck (Zodiac, CaesarStone...)
- Millwork Body Panels
- Stone or Ceramic Tile "Tiled at the Factory" Body Panels
- Plastic Laminate Body Panels
- Back Lighted Body Panels
- Stainless Steel Folding Work Shelf
- Bullet Feet
- Correctional Package
- Field Measurement
- Installation

### PRODUCT INFORMATION

■ **Design & Construction:** 18 ga. stainless steel frame construction with welded vertical corner supports and 16 ga. stainless steel top. Stainless steel removable front & end panels and 3" diameter adjustable casters.

■ **Design Features:** Counter to accommodate various tray sizes: 12" x 20", 10" x 15", 15" x 20", 14" x 18", 13" x 21", 16" x 22", 17½" x 21"; Specify tray size. Includes 3 bins for silver or plastic ware. Optional round bins and configurations available.



# Tray and Silveware Counter

TS-28-AF, TS-32-AF

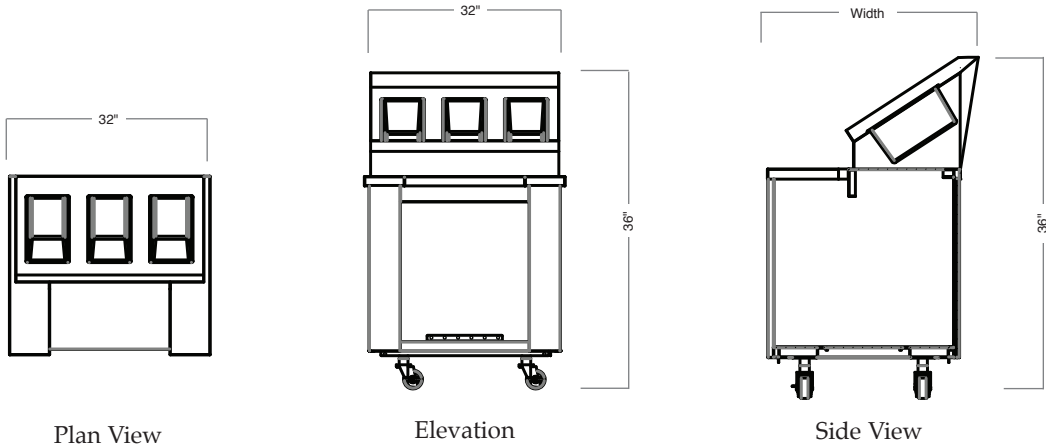

## TECHNICAL SPECIFICATIONS

Model Number	Length	Width	Height	Shipping Wt. Lbs.	Locking Direction
TS-28-AF	32"	28½"	36"	225	Not Applicable
TS-32-AF	32"	32"	36"	250	Specify (L) Left or (R) Right for Locking Post



Savannah, TN 38372 [www.americanfoodserviceco.com](http://www.americanfoodserviceco.com)  
731-925-2200 / 800-447-4693 / FAX 731-925-2840

Due to continued product improvement, specifications are subject to change without notice.

9/01/11 USA