

(Shown with optional trayslide,  
workshelf and breath protector.)

## Frost Top Counter

### Model

FT-38-AF

FT-52-AF

FT-66-AF

FT-80-AF

FT-94-AF

### OPTIONAL FEATURES

- Solid Surface Top Deck (Corian...)
- Stone Top Deck (Zodiac, CaesarStone...)
- Stainless Steel Tray Slide
- Solid Surface Tray Slide (Corian...)
- Stone Tray Slide (Zodiac, CaesarStone...)
- Millwork Body Panels
- Stone or Ceramic Tile "Tiled at the Factory" Body Panels
- Plastic Laminate Body Panels
- Solid Surface Material Body Panels
- Back Lighted Body Panels
- Stainless Steel Folding Work Shelf
- Folding Work Shelf with NSF Approved Plastic Cutting Board
- Folding Work Shelf with Hardwood Cutting Board
- Folding Work Shelf with Heat Resistant Richlite
- Breath Protectors: Fixed
- Breath Protectors: Adjustable
- School or Company Logo
- Electrical Raceway and Junction Box
- Bullet Feet
- Correctional Package
- Field Measurement
- Installation

### PRODUCT INFORMATION

■ **Design & Construction:** 18 ga. stainless steel frame construction with welded vertical corner supports and 16 ga. stainless steel top. Installed in the top is a raised refrigerated frost top. These units include a full length stainless steel under-shelf, stainless steel removable front & end panels and 3" diameter adjustable casters.

■ **Design Features:** Frost top is raised 1-1/2" and sloped to 1/2" drain. Undershelving is provided with a rear turn-up and is held short to create a utility access area without blocking the storage space.



# Frost Top Counter

**FT-38-AF, FT-52-AF, FT-66-AF, FT-80-AF, FT-94-AF**

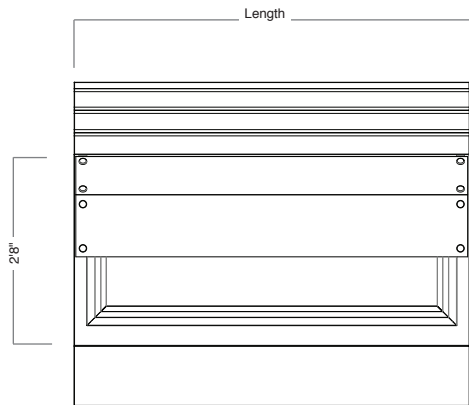

Plan View

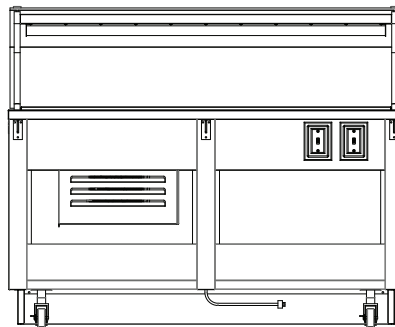

Elevation

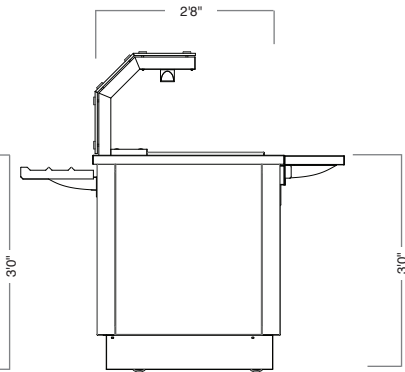

Side View

(Shown with optional trayslide, workshelf and breath protector.)

## TECHNICAL SPECIFICATIONS

Model Number	Length	Width	Height	Volts	Phase	HP	Amps	NEMA Plug	Shpg. Wt. Lbs.
FT-38-AF	38"	32"	36"	120	1	1/4	6	5-15P	370
FT-52-AF	52"	32"	36"	120	1	1/4	6	5-15P	460
FT-66-AF	66"	32"	36"	120	1	1/4	6	5-15P	510
FT-80-AF	80"	32"	36"	120	1	1/3	8	5-15P	590
FT-94-AF	94"	32"	36"	120	1	1/3	8	5-15P	660



Savannah, TN 38372 [www.americanfoodserviceco.com](http://www.americanfoodserviceco.com)  
731-925-2200 / 800-447-4693 / FAX 731-925-2840

Due to continued product improvement, specifications are subject to change without notice.

9/01/11 USA