

Cashier Counter

Model

CC-30-AF

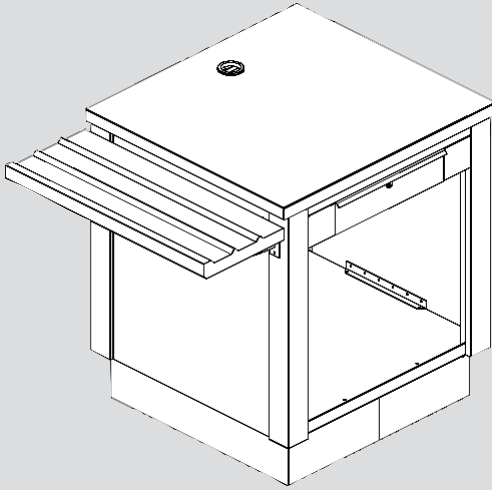

(Shown with optional trayslide)

OPTIONAL FEATURES

- Solid Surface Top Deck (Corian...)
- Stone Top Deck (Zodiac, CaesarStone...)
- Stainless Steel Tray Slide
- Solid Surface Tray Slide (Corian...)
- Stone Tray Slide (Zodiac, CaesarStone...)
- Millwork Body Panels
- Stone or Ceramic Tile "Tiled at the Factory" Body Panels
- Plastic Laminate Body Panels
- Solid Surface Material Body Panels
- Back Lighted Body Panels
- School or Company Logo
- Electrical Raceway and Junction Box
- Bullet Feet
- Correctional Package
- Field Measurement
- Installation

PRODUCT INFORMATION

■ **Design & Construction:** 18 ga. stainless steel frame construction with welded vertical corner supports and 16 ga. stainless steel top. These units include a stainless steel cash drawer, 1-5/8" o.d. stainless steel tubular footrest, stainless steel removable front & end panels and 3" diameter adjustable casters.

■ **Design Features:** Stainless steel cash drawer to be 16¼" x 17½" x 4" with keyed lock and removable currency insert. One (1) 120V NEMA 5-15R receptacle provided.



Cashier Counter

CC-30-AF

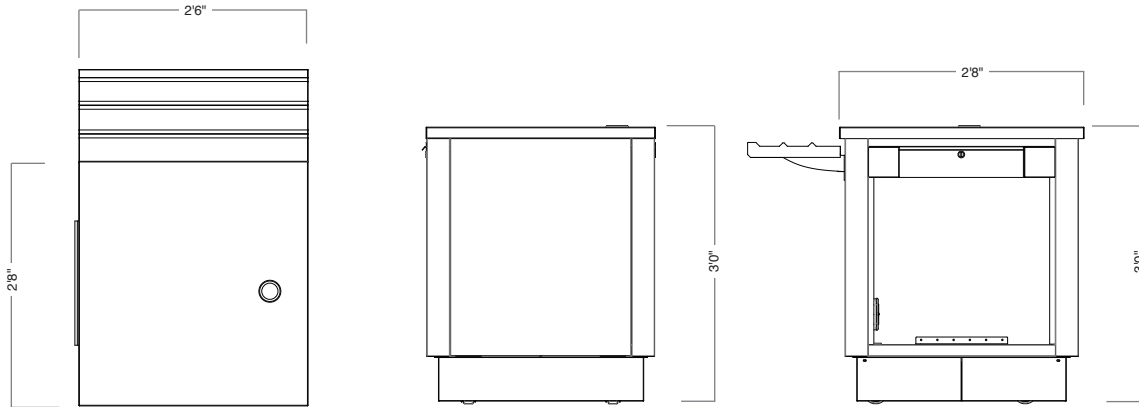

Plan View

Elevation

Side View

(Shown with optional trayslide)

TECHNICAL SPECIFICATIONS

Model Number	Length	Width	Height	Shipping Wt. Lbs.	Electrical
CC-30-AF	30"	32"	36"	250	120V NEMA 5-15P



Savannah, TN 38372 www.americanfoodserviceco.com
731-925-2200 / 800-447-4693 / FAX 731-925-2840

Due to continued product improvement, specifications are subject to change without notice.

9/01/11 USA